

SCHEMATIC DESIGN

MEETING

Suzhou Sangha
Event Center B6

JUNE 18, 2015

BALLROOM

OVERALL PLAN

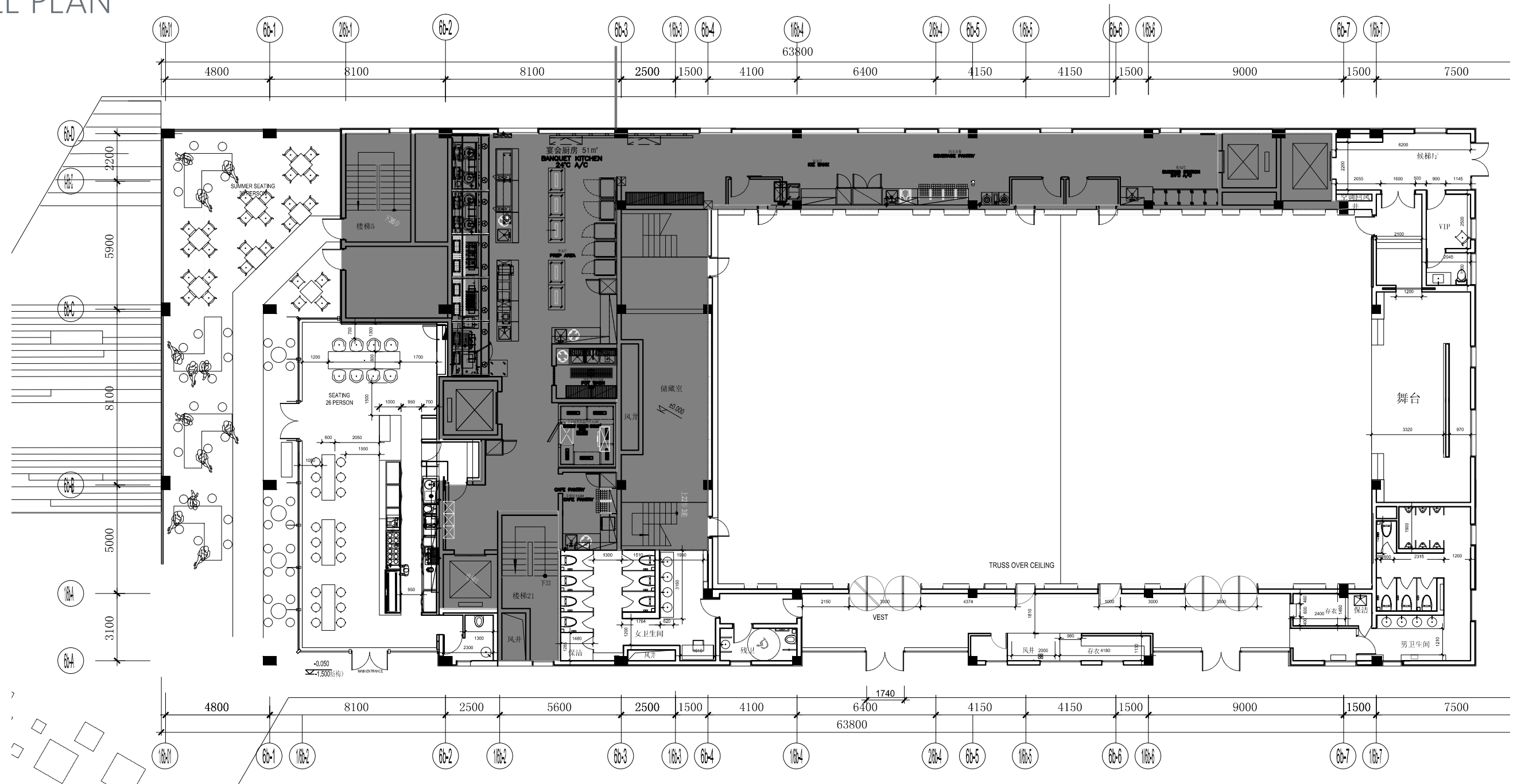

CEILING TRUSS

BALLROOM

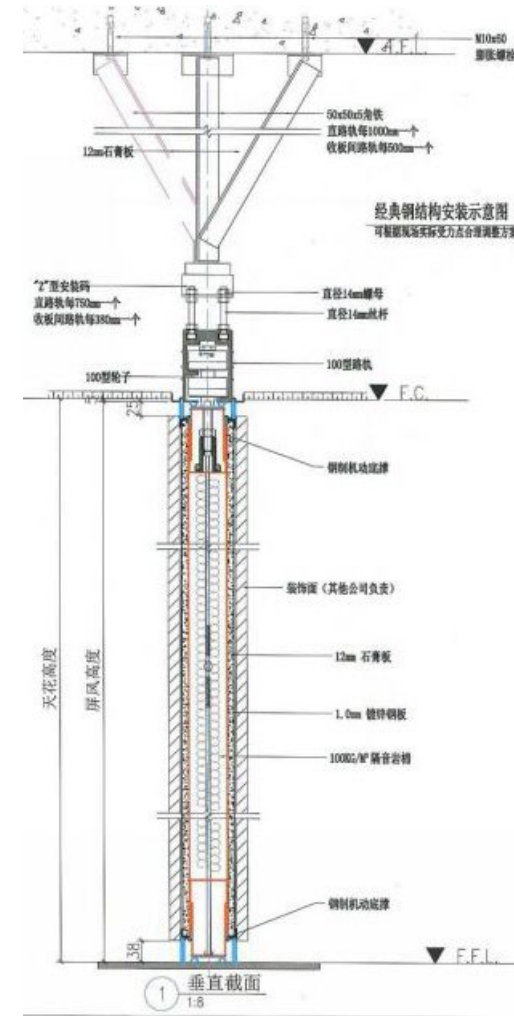
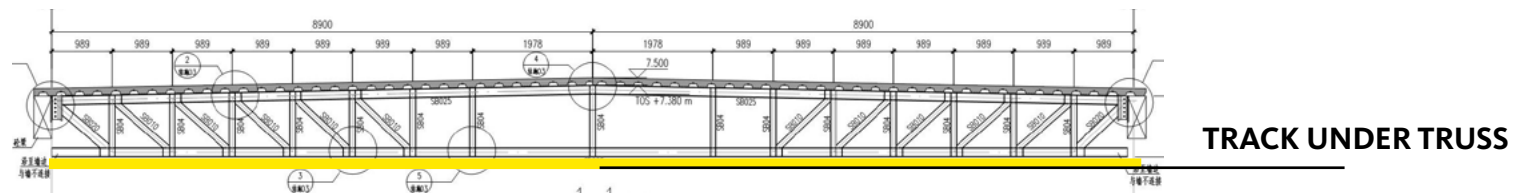
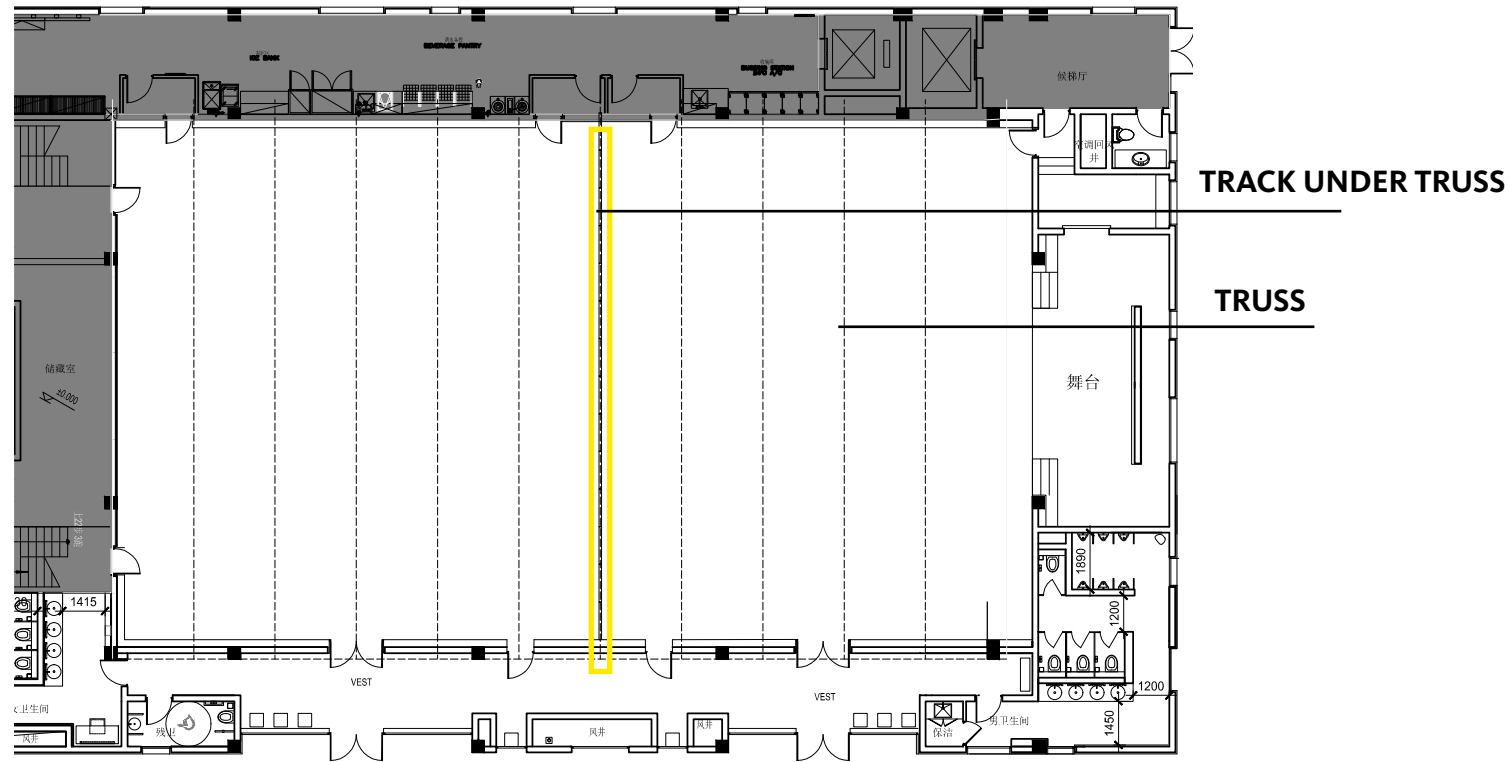

- 1) 新型隔断内框结构设计、配合崭新牛鼻设计，成熟完整的整体隔音处理，提高隔音效果，最高可达STC60

 - 隔断顶部及底部的4层式垂直密封胶条，立体多层次的隔音密封胶的融合设计，使隔音进一步提升。

隔断防火设计领先行业水准

- 隔断防火等级达到3小时，领先行业标准。

新型隔断碰撞接口位置设计

- 新型隔断内框结构设计、配合崭新牛鼻设计，成熟完整的整体隔音处理，
- 提高隔音效果，最高可达STC60

BALLROOM OPTION 1

PARTITION WALL

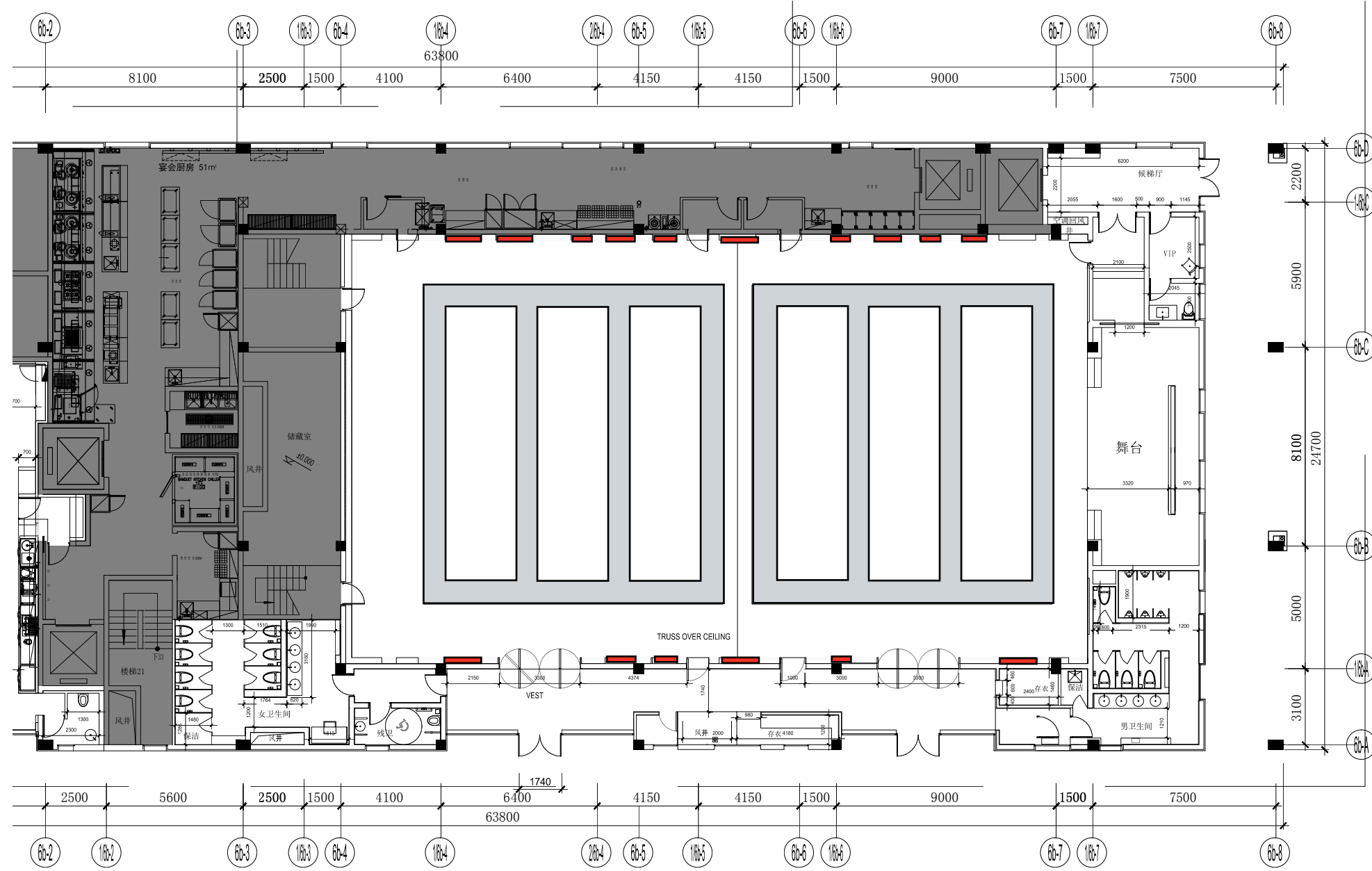

- PARTITION WALL
- OPEN CEILING

BALLROOM OPTION 1

PARTITION WALL

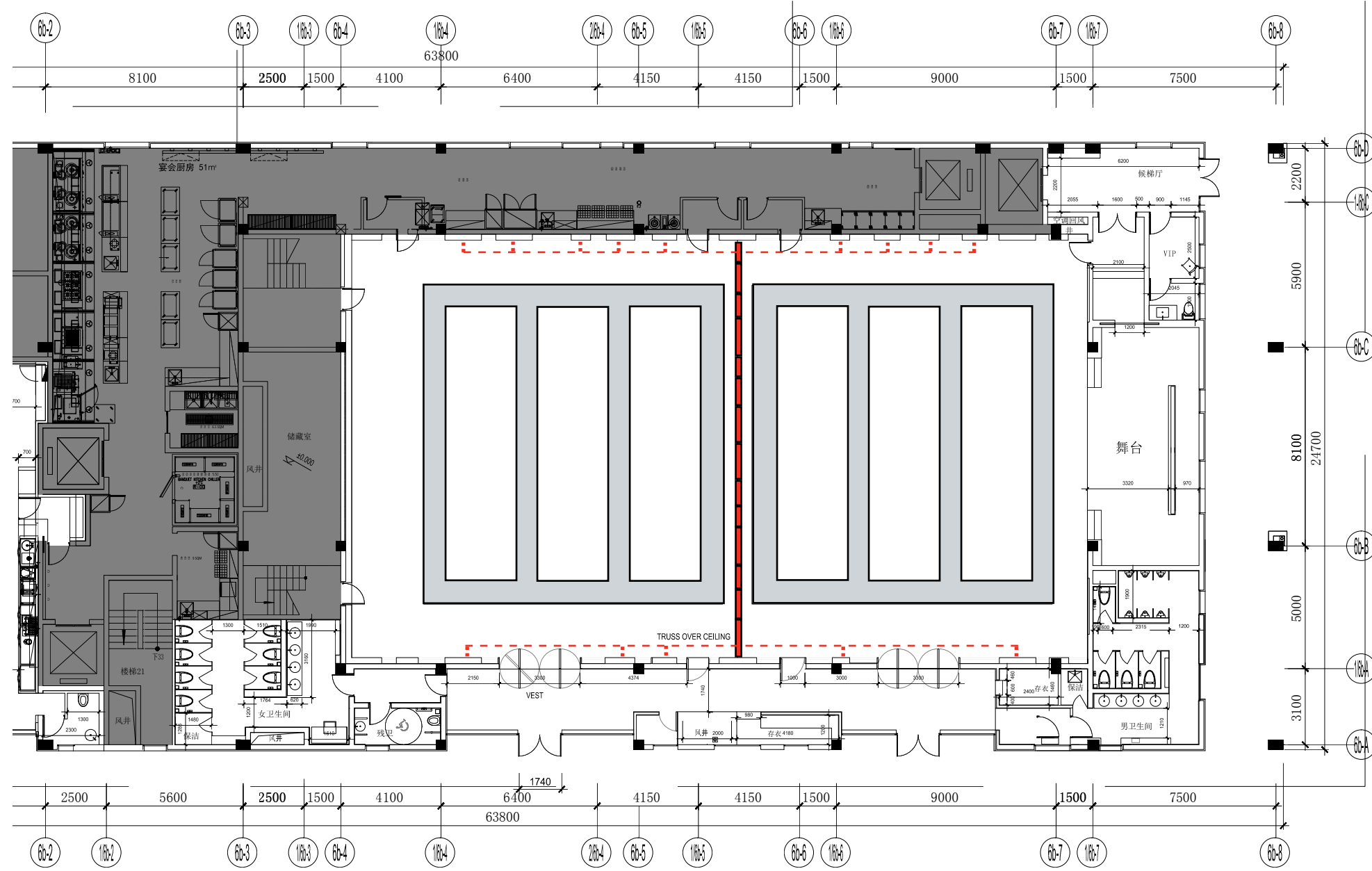

- PARTITION WALL
- OPEN CEILING

BALLROOM OPTION 1

CEILING MEP

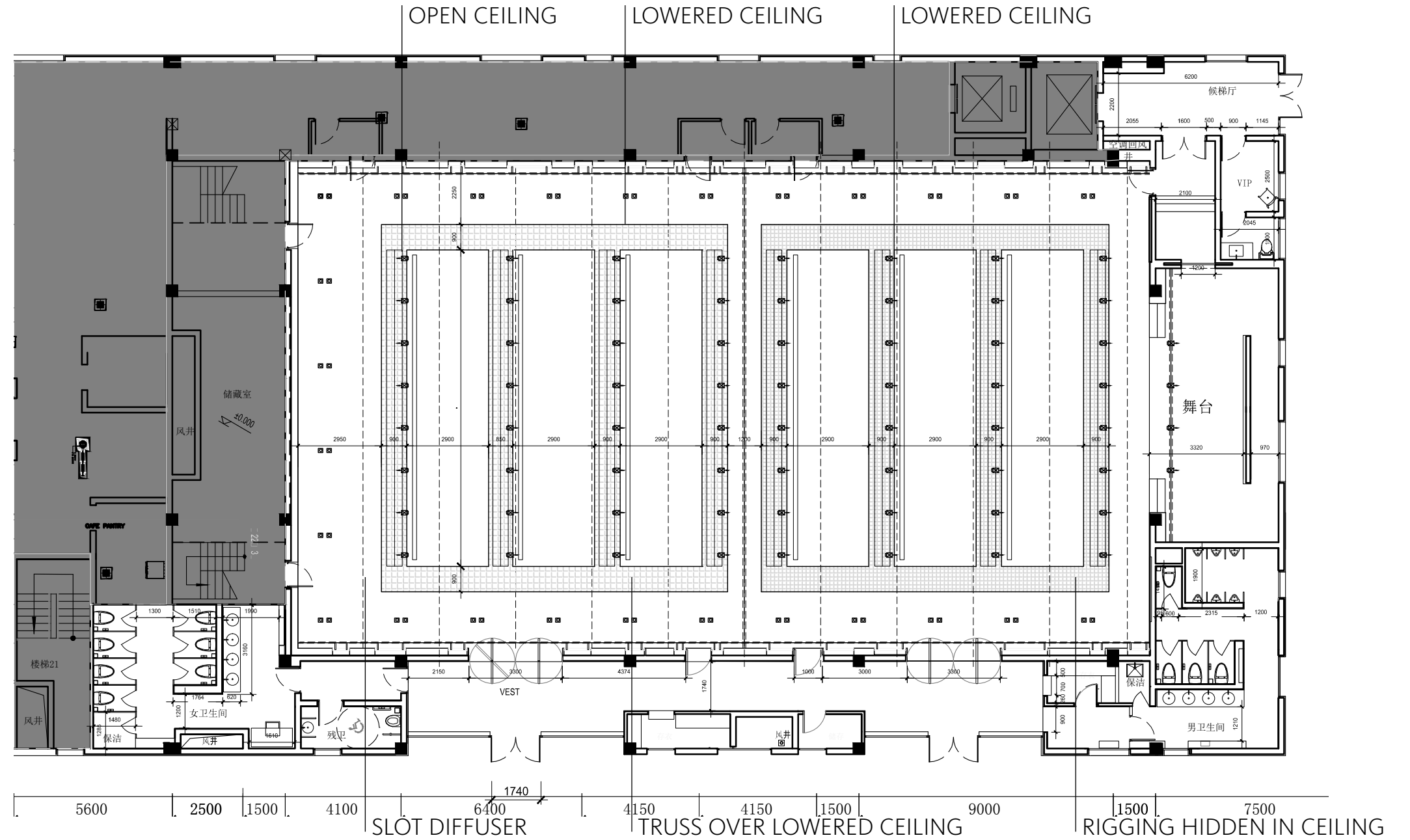

BALLROOM OPTION 1

LOOK & FEEL



WALL FINISH WITH ACOUSTIC PERFORATION



LIGHTER OVERALL FEEL



RHYTHMIC WALL PANELING



DIGITAL EXPERIENCE



WOOD FLOOR

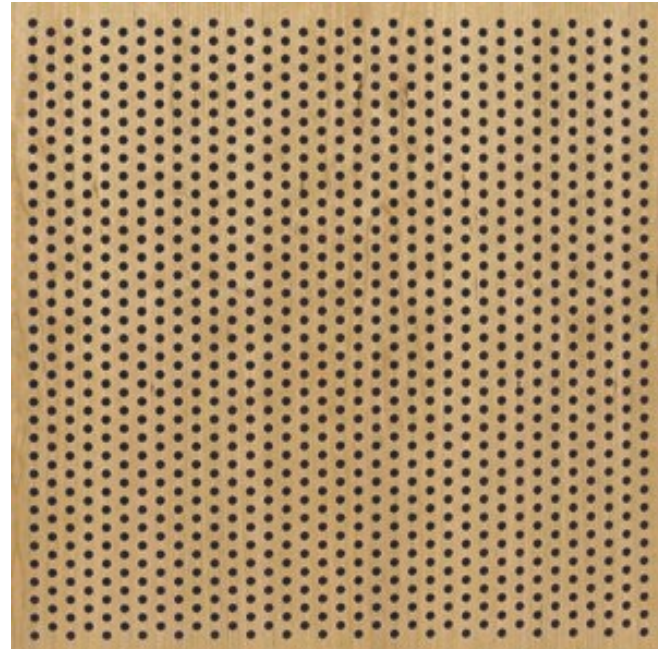

ACOUSTIC PERFORATION CLOSE UP



ACOUSTIC CEILING (DARK GREY)

BALLROOM

MATERIALS: OPTION 1

WHITE ACOUSTIC CEILING

**WOOD WALL FINISH
WITH ACOUSTICAL PERFORATION**

**SEMI-TRANSPARENT MIRROR
LOW IRON GLASS:
IN FRONT OF WALL LED**

OAK WOOD FLOOR

**MATT BLACK METAL
FOR LED PANEL FRAME/
DOORS**



BALLROOM OPTION 1

3D PERSPECTIVE



PLAN COLORED

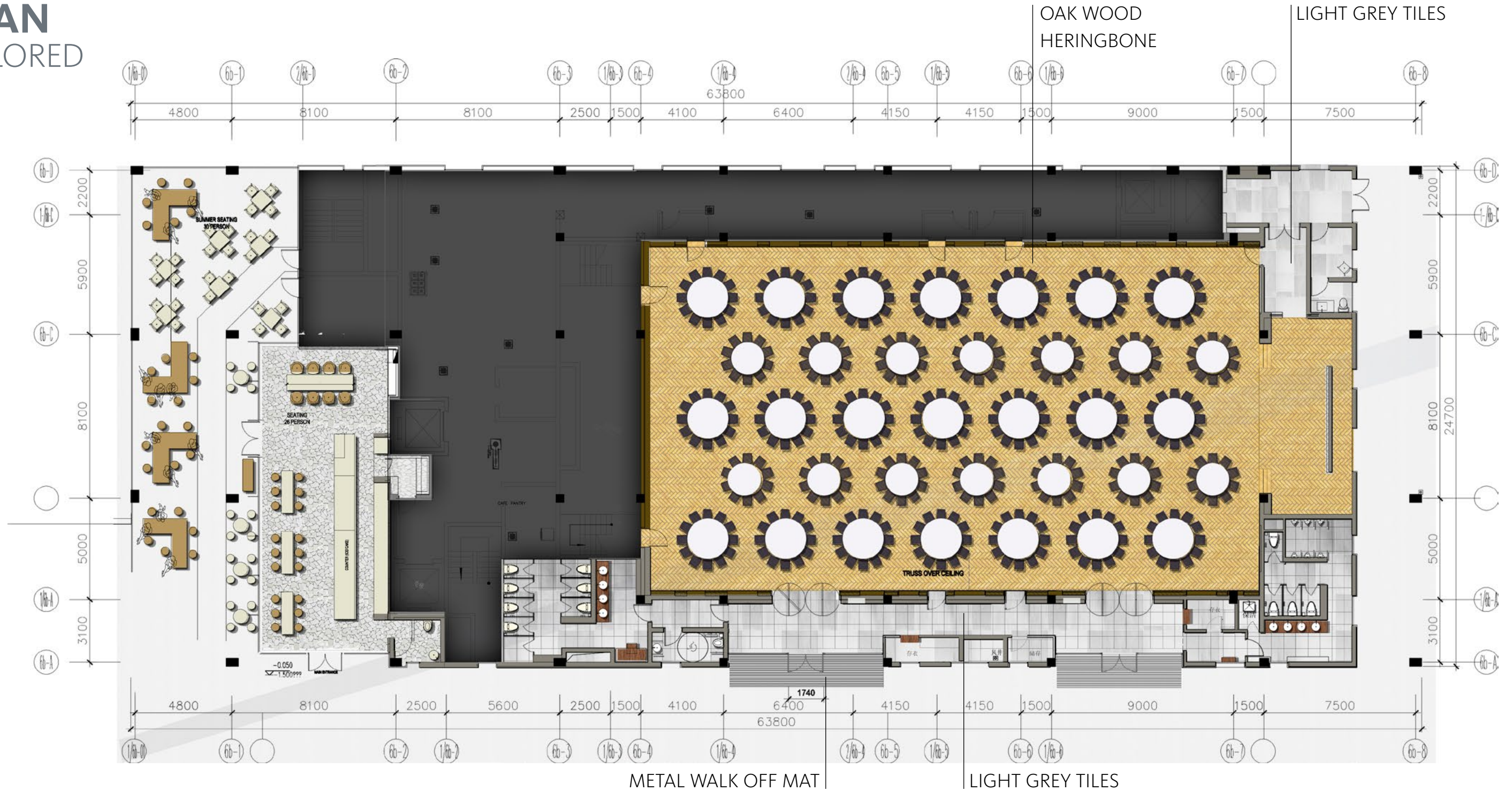

BALLROOM OPTION 1

ELEVATIONS

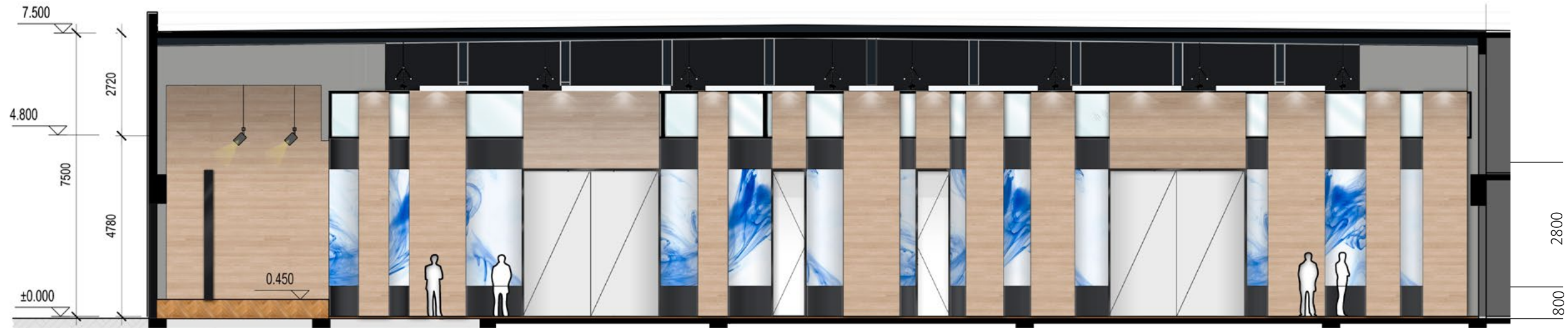

TOWARDS VESTIBULE



TOWARDS KITCHEN

BALLROOM OPTION 1

DIFFERENT SCENARIOS

SCREENS ON LONG WALL: 73.2 M2
SCREENS ON STAGE: 32M2



NATURAL TRADE FAIR SCENARIO



WEDDING SCENARIO

BALLROOM OPTION 1

ELEVATIONS

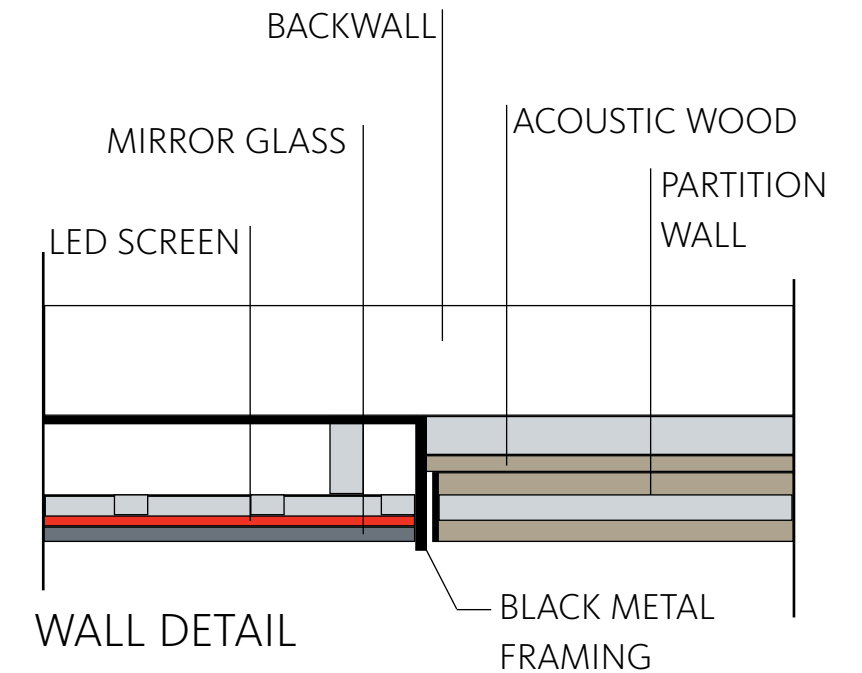
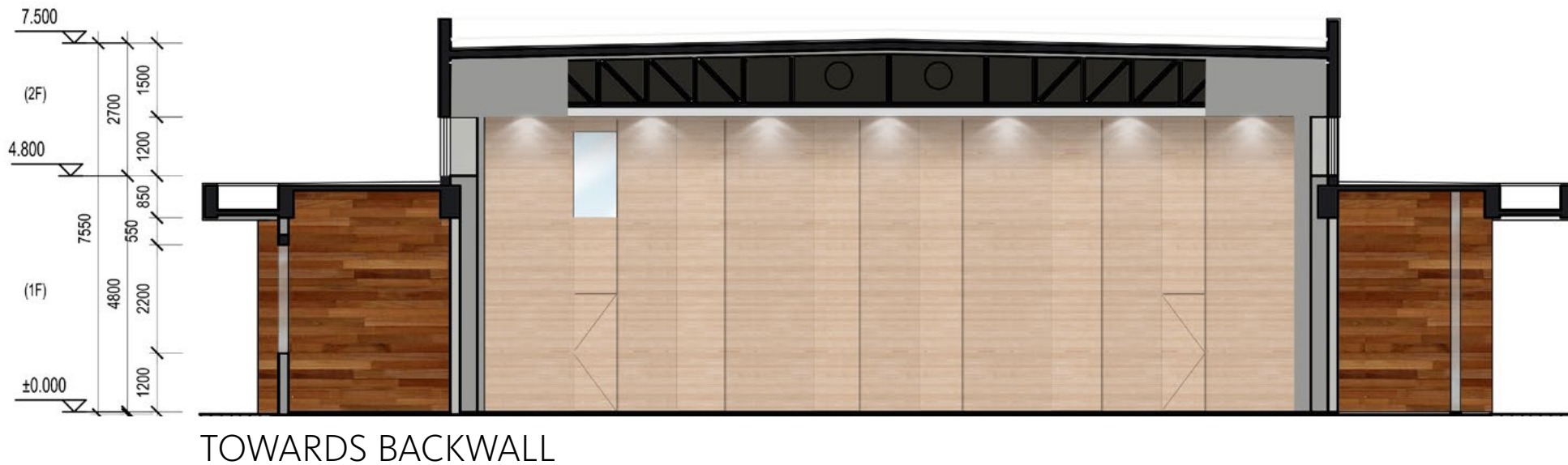

BALLROOM OPTION 2

PARTITION WALL

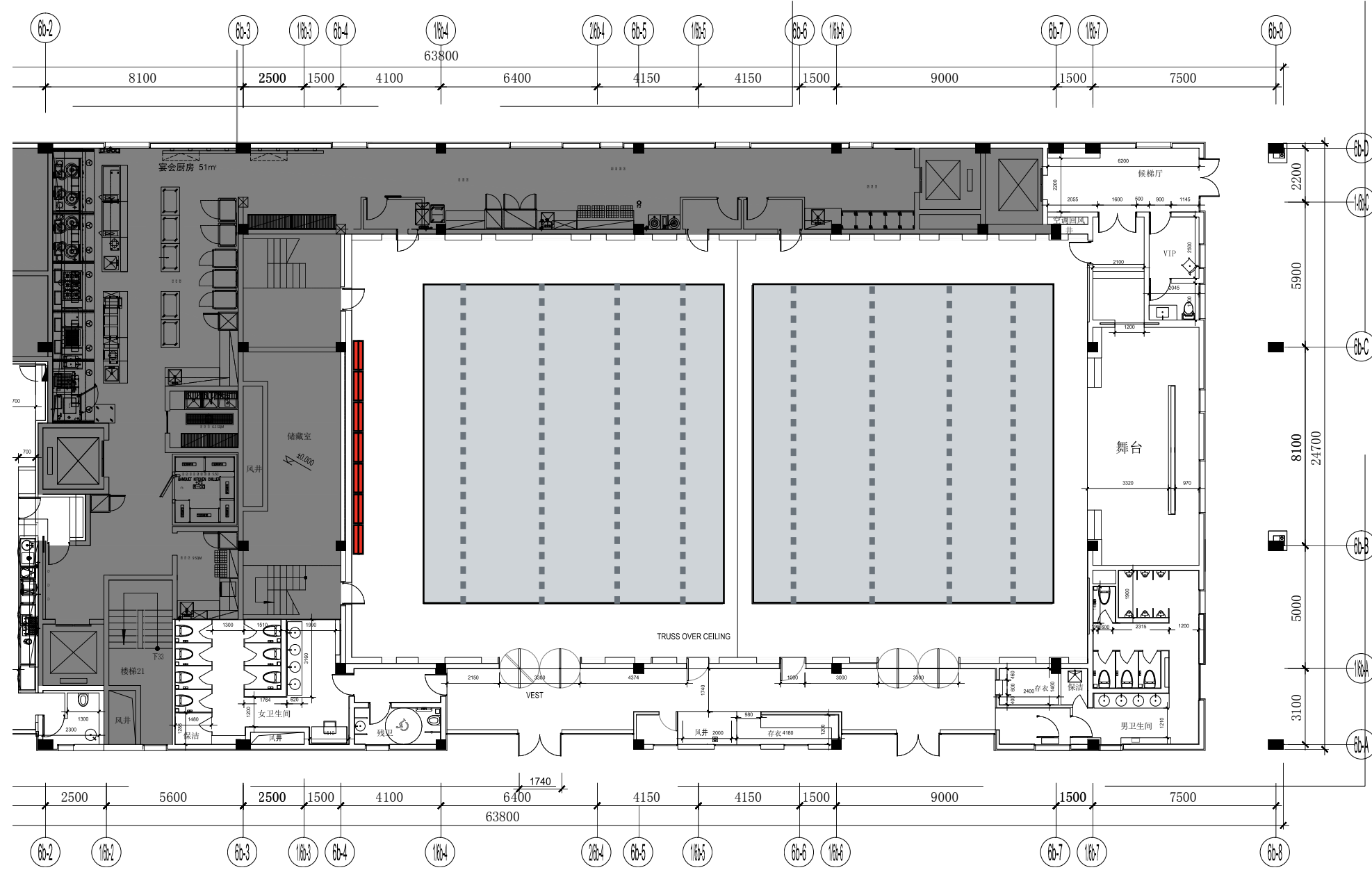

BALLROOM OPTION 2

PARTITION WALL

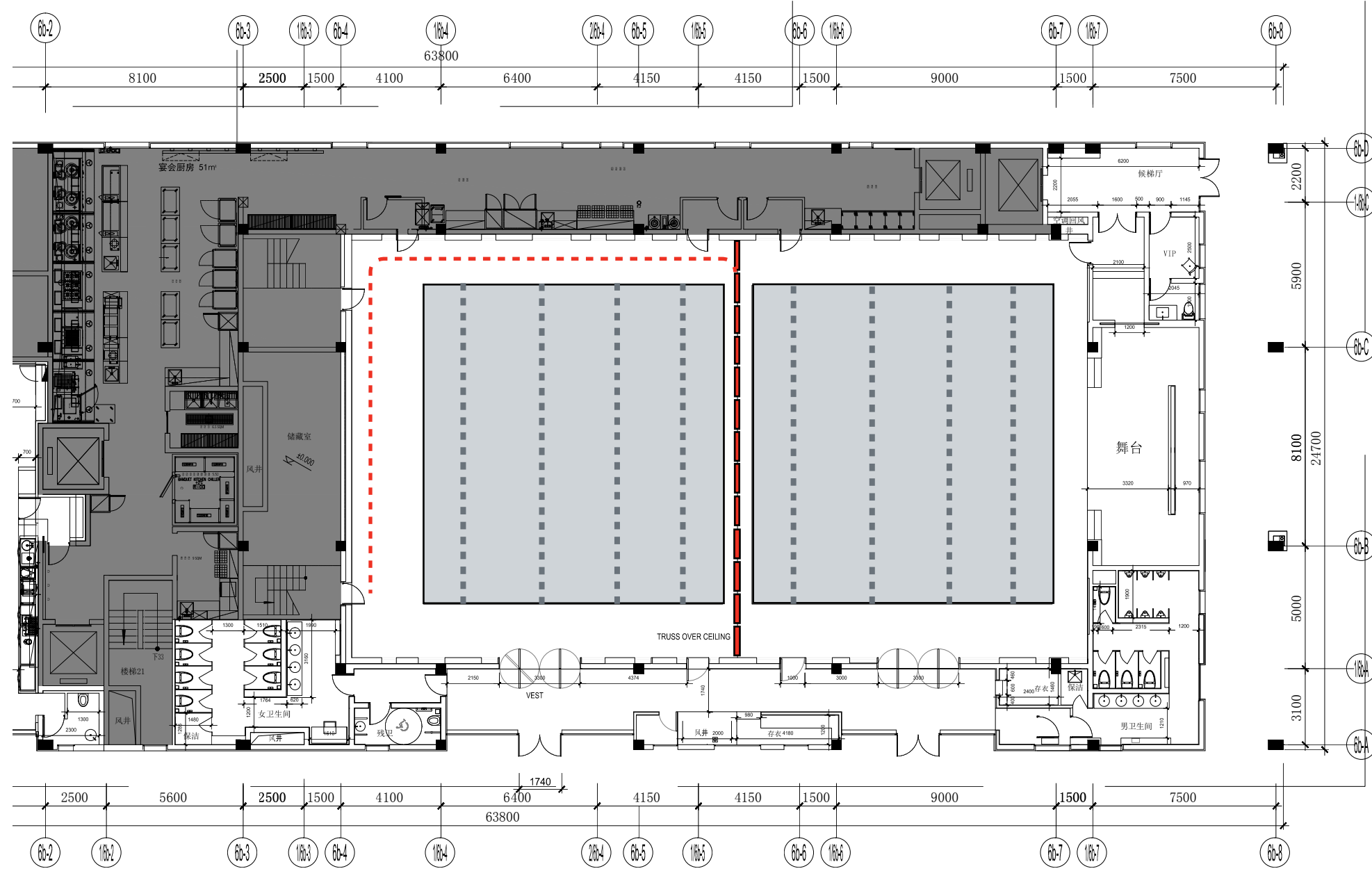

- TRUSS
- PARTITION WALL
- OPEN CEILING

BALLROOM OPTION 2

CEILING M&P

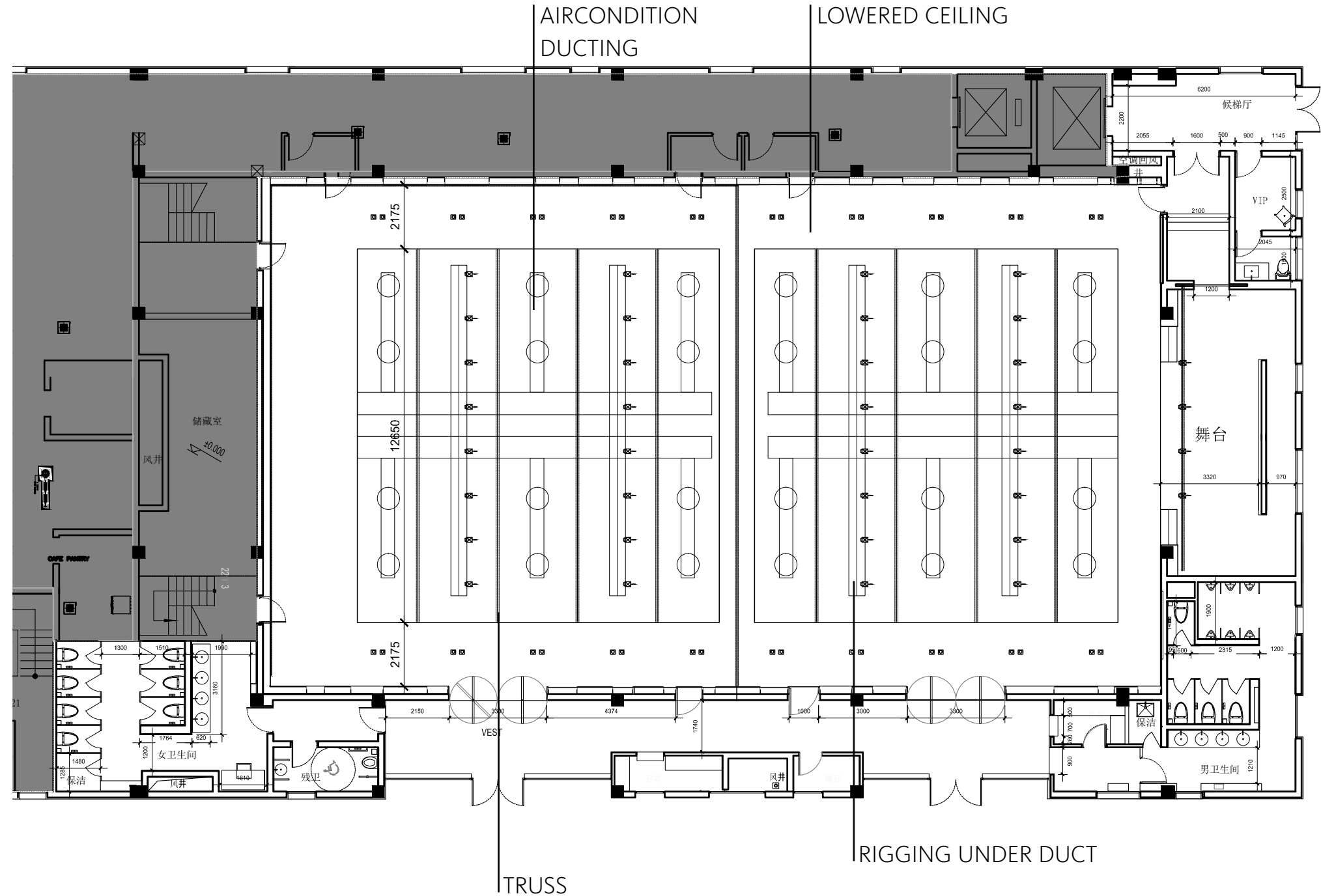

BALLROOM OPTION 2

LOOK & FEEL

PIVOT DOORS



RANDOM LOUVERS

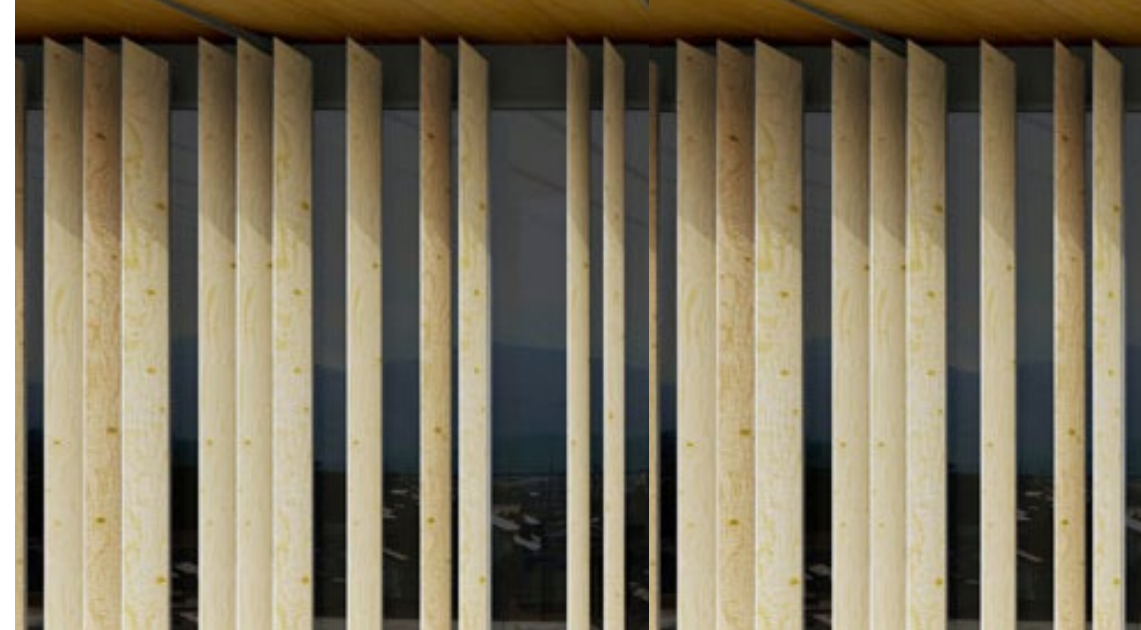

MIRROR GLASS



WOOD FLOOR



ACOUSTIC CEILING (DARK GREY)



ACOUSTIC WHITE WALL



BUILDING ARCHITECTURE

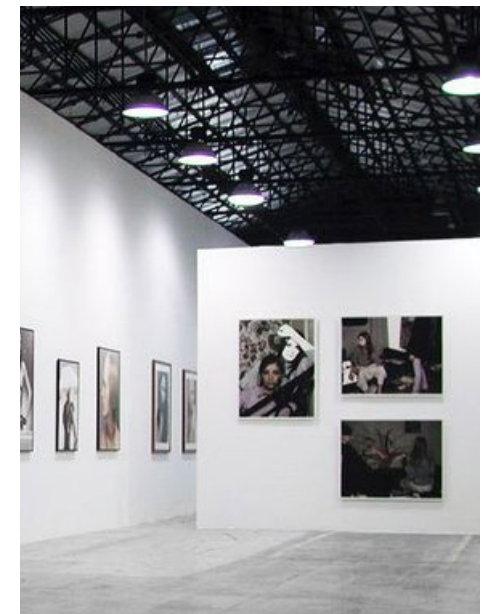

BALLROOM

MATERIALS: OPTION 2

WHITE ACOUSTIC CEILING

WALL LOUVER: WOOD FILM ON MDF

BASEWALL BEHIND LOUVER:

OPTION 1: WALL ACOUSTIC PANEL

PERFORATED BLACK MDF

FOR WALL IN STAGE AREA

BASEWALL BEHIND LOUVER:

OPTION 2: UPHOLSTERED PANEL (FABRIC)

SEMI-TRANSPARENT MIRROR

LOW IRON GLASS: IN FRONT OF WALL LED

ACOUSTIC CEILING PANEL

TO COVER SPACE OVER TRUSS

OAK WOOD FLOOR

(HERINGBONE)

MATT BLACK METAL

**FOR LED PANEL FRAME/
DOORS**

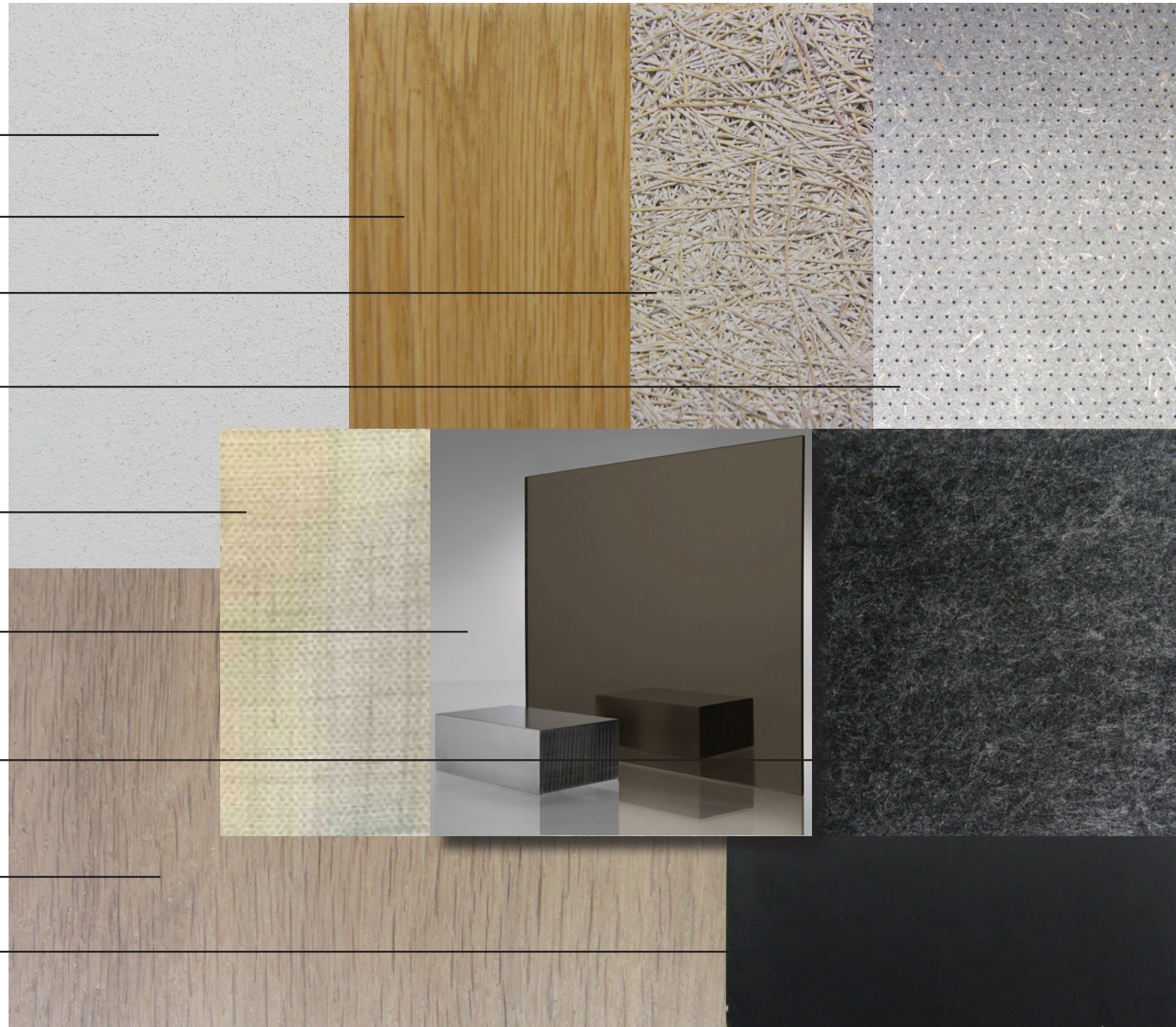

BALLROOM OPTION2

3D PERSPECTIVE



BALLROOM OPTION 2

ELEVATION

SCREENS ON LONG WALL: 78.7 M²
SCREENS ON STAGE: 32M²



TOWARDS VESTIBULE



TOWARDS KITCHEN

BALLROOM OPTION2

ELEVATION



TOWARDS STAGE



TOWARDS BACKWALL

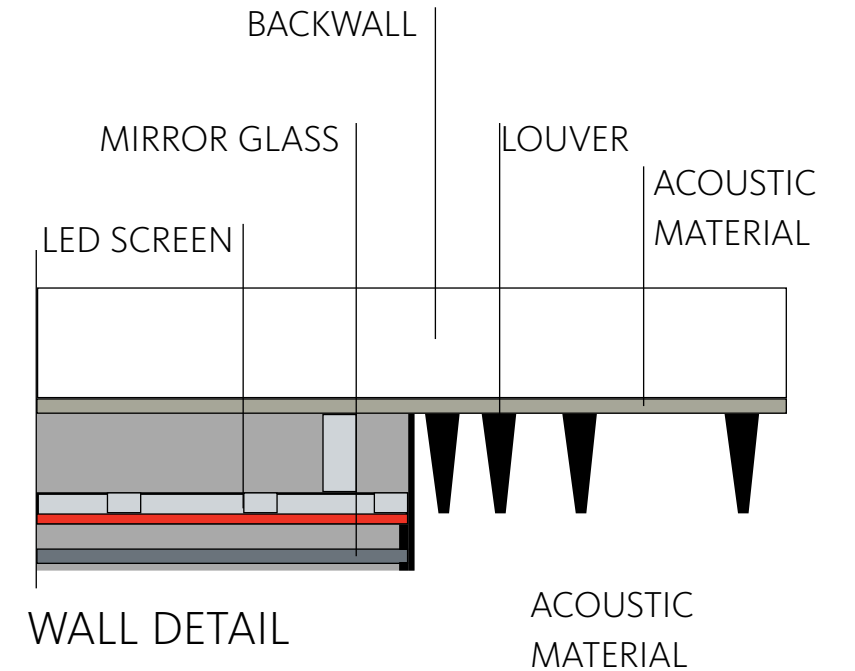

VESTIBULE

LOOK & FEEL

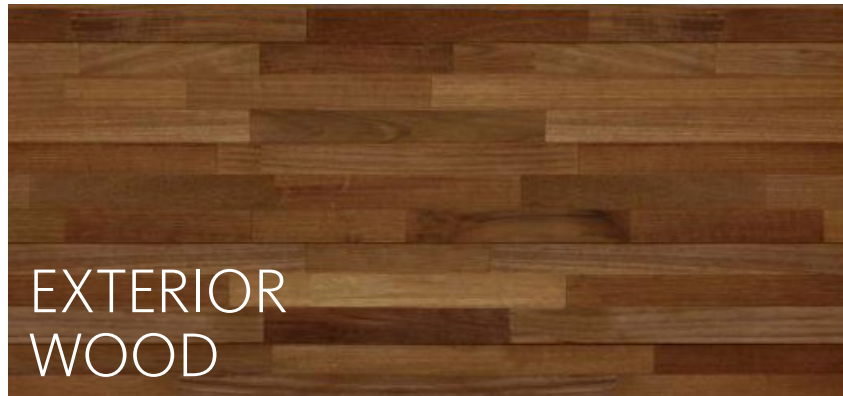

EXTERIOR
WOOD



INTERIOR
TILE WALL



PIVOT DOORS



EXTERIOR



SIGNAGE



WALL FINISH



FLOOR FINISH

ENTRY VESTIBULE AND RESTROOMS MATERIALS

RESTROOM WALL WOOD

BALLROOM DOOR BLACK MATT METAL

RESTROOM WALL TILE

**EXTERIOR WOOD CONTINUED INTO
VESTIBULE**

**METAL WALK OFF MATT
FLOOR OUTSIDE VESTIBULE**

**ENTRY VESTIBULE WALL TILE
(PRELIMINARY SAMPLE)**

**RESTROOM/ VESTIBULE FLOOR
TILE 600X600**



BALLROOM

COLORED PLAN VESTIBULE AREA

DIGITAL
DIRECTORY

DIGITAL
DIRECTORY



ELEVATIONS



ELEVATION A

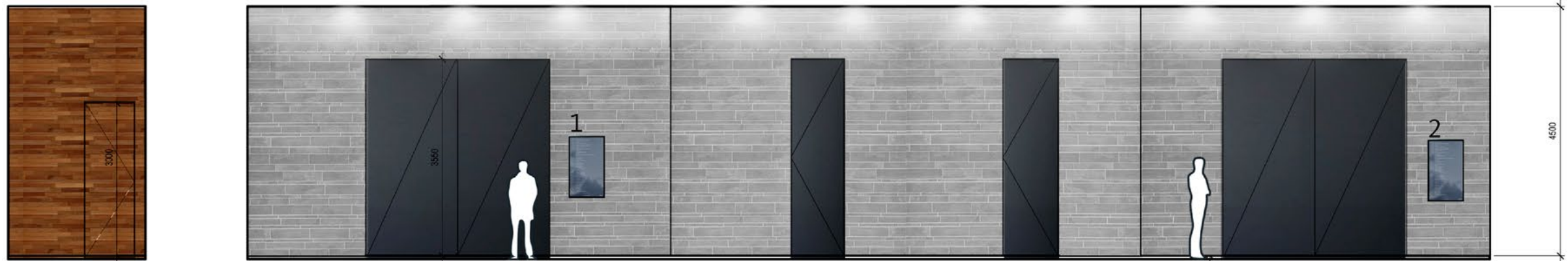

ELEVATION B

RESTROOMS

LOOK & FEEL



MATT METAL
PARTITION



ACCENT
PENDANT



RECESS
LIGHTING



COUNTER
FURNITURE

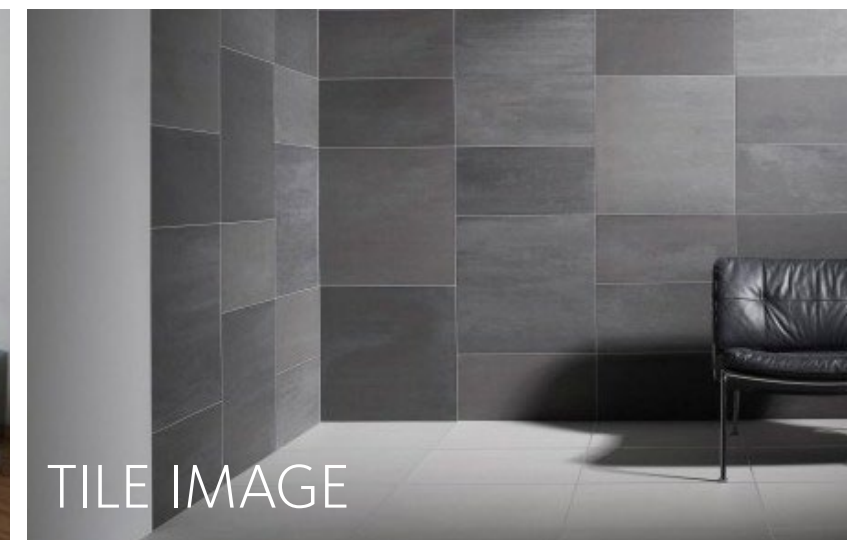

TILE IMAGE

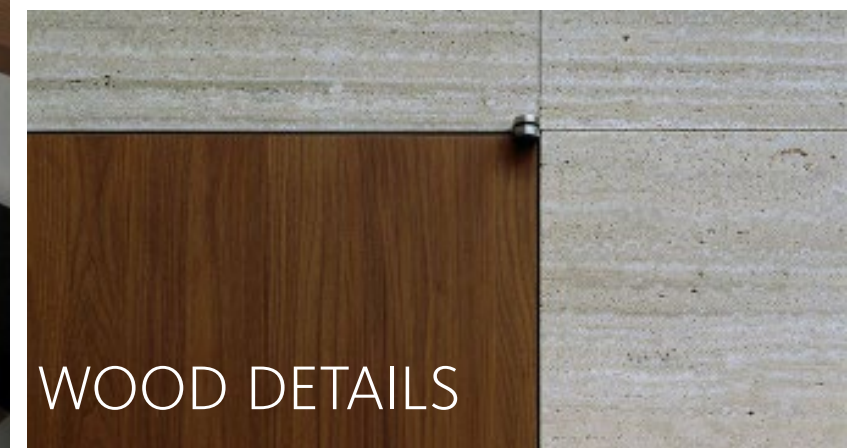

WOOD DETAILS

BALLROOM

RESTROOMS

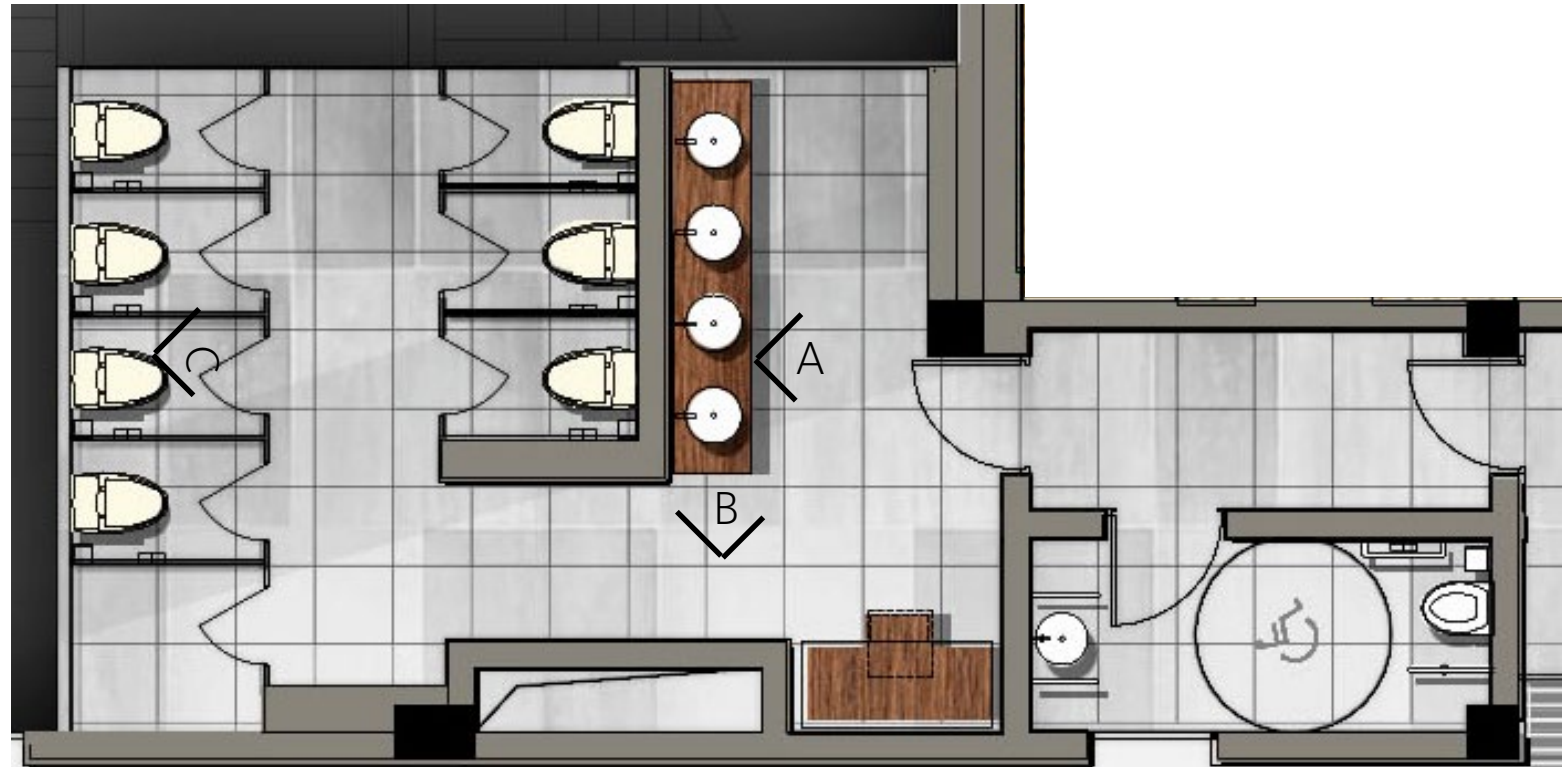

FEMALE TOILET & DISABLE TOILET

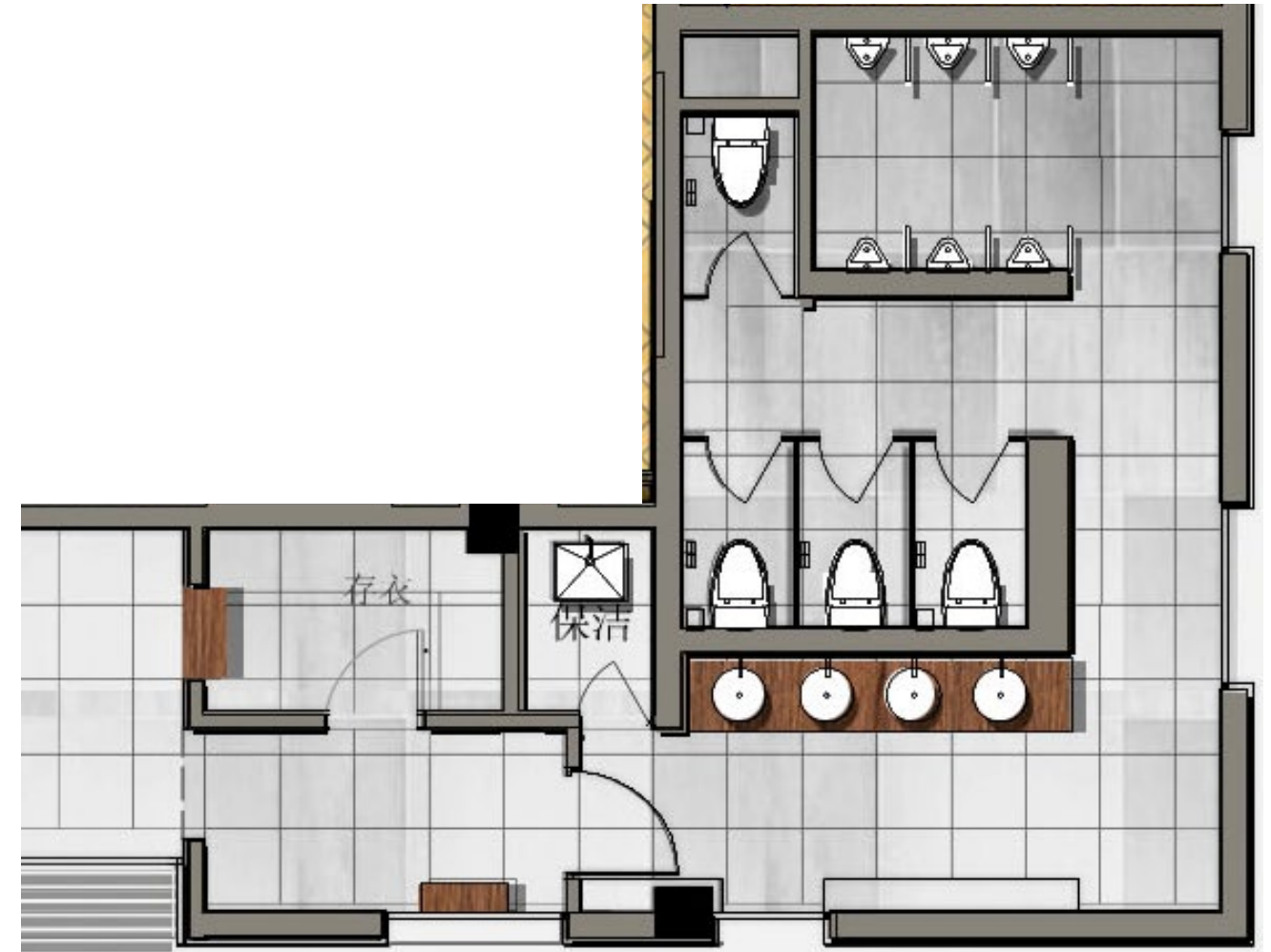

MALE TOILET

RESTROOM ELEVATION

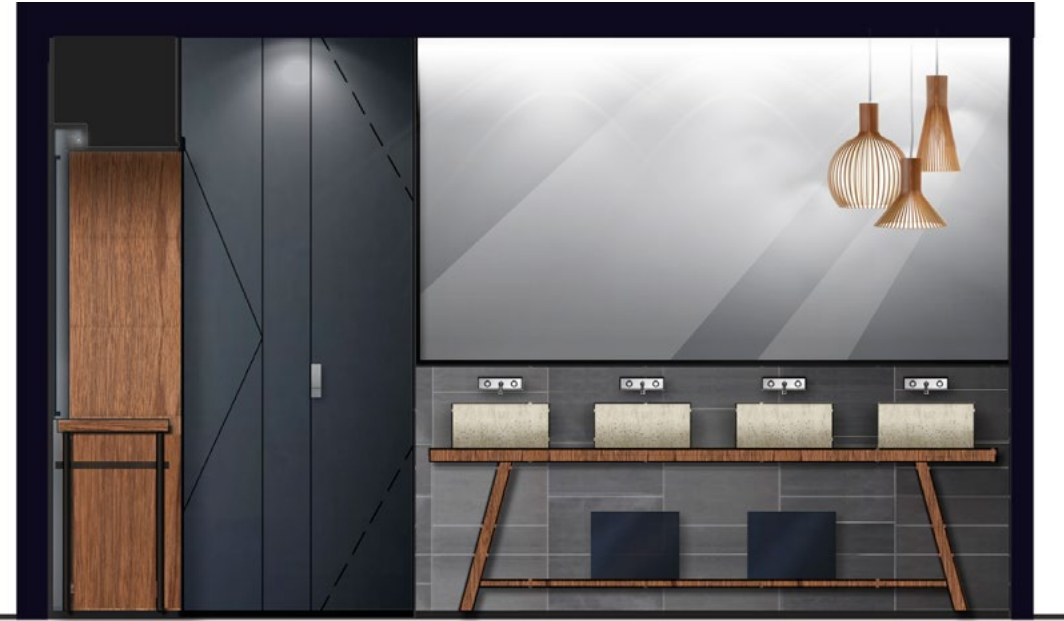

ELEVATION A

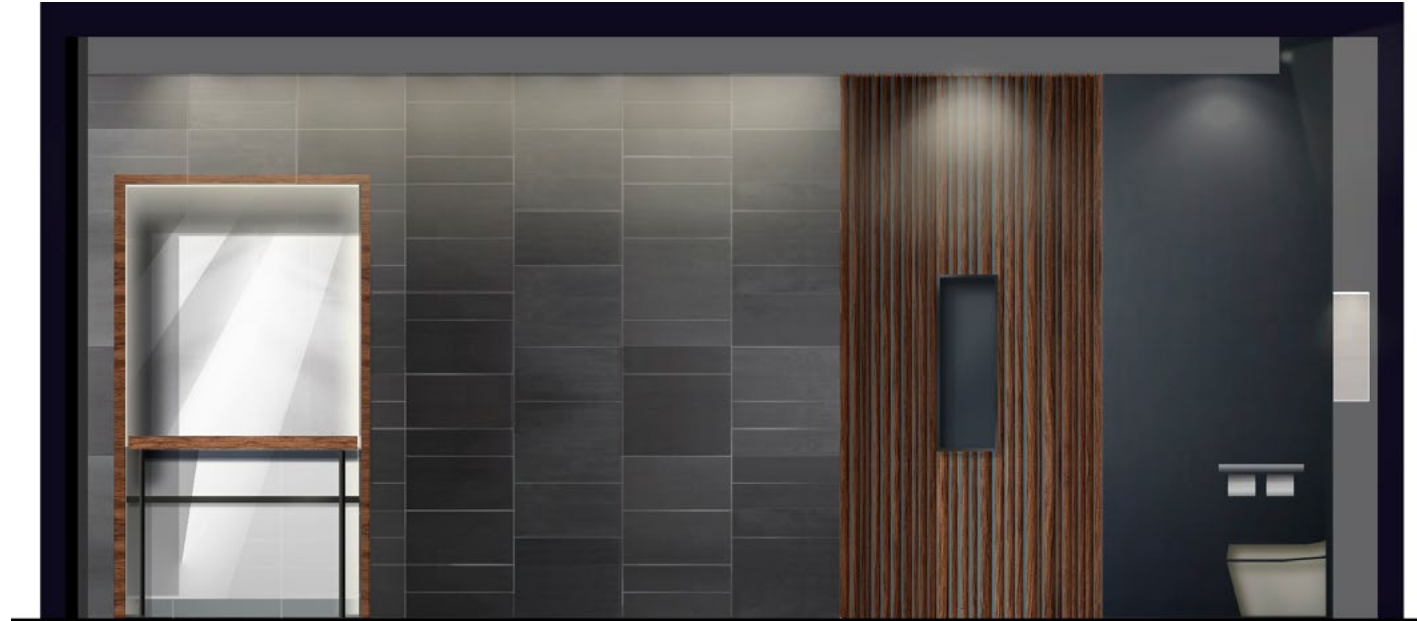

ELEVATION B

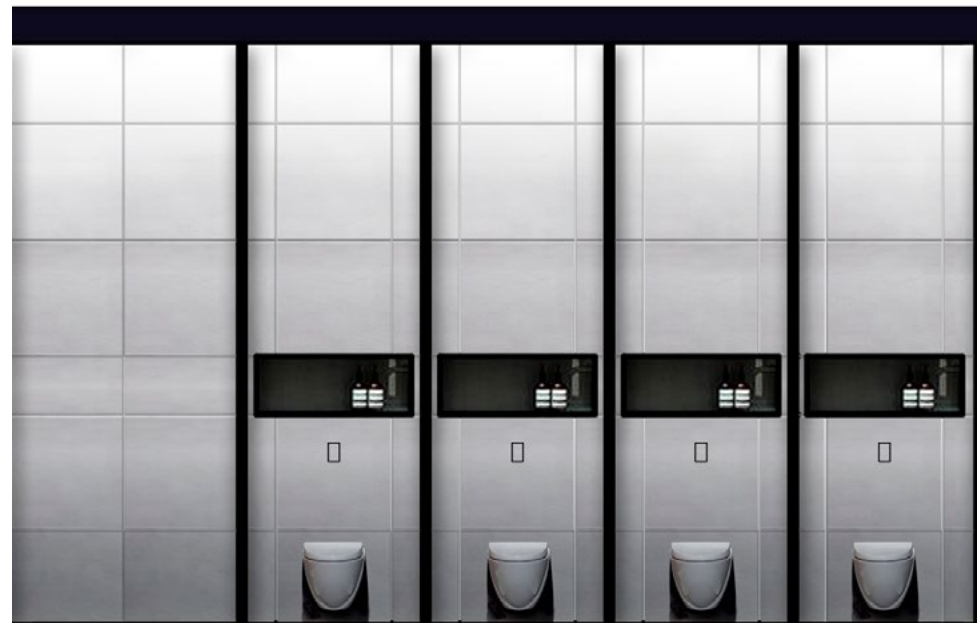

ELEVATION C

CAFE

FF+E



BAR FRONT / MAIN FLOOR



PARTIAL WALL FINISH

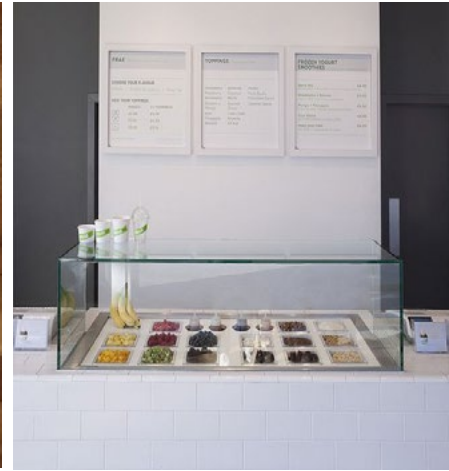

EQUIPMENT STYLE



COMMUNAL



BACK COUNTER

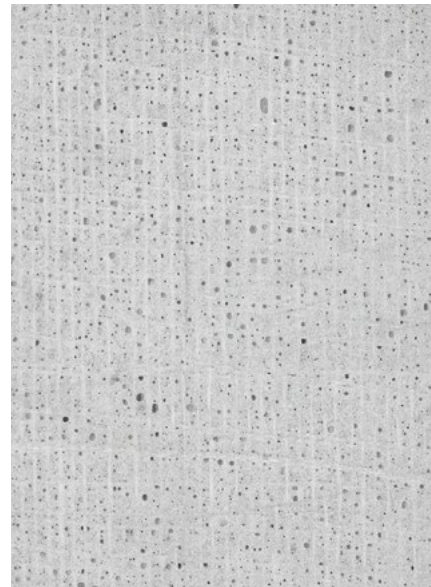

WALL FINISH



HIGH TABLE IMAGE



COMMUNAL TABLE CHAIR



BAR STOOL

CAFE

FF+E - OUTDOOR SEATING

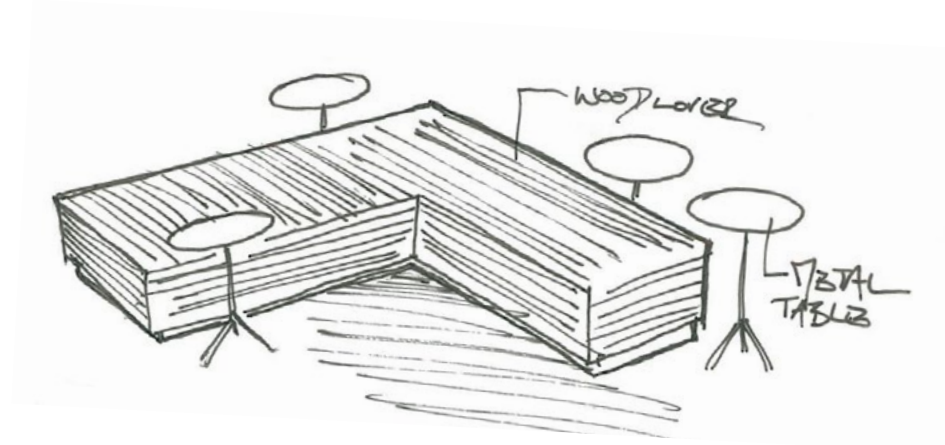

TEMPORARY OUTDOOR SEATING TABLE (NOT FOR COLOR INDICATION)



PERMANET OUTDOOR SEATING LOOK & FEEL



COFFEE SHOP

MATERIALS

TERRAZZO: FLOOR AND COUNTERTOP

MATT BLACK METAL

MULLION MATERIAL / OUTDOOR TABLE

CONCRETE WALL

WHITE CORIAN

BAR COUNTER INSIDE DISPLAY (OPTION 2)

FURNITURE/ BACK COUNTER WOOD

BUILDING WOOD EXTERIOR

CARRYING INTO COFFEE SHOP

BAR COUNTER METAL INSIDE

DISPLAY (OPTION 1)



CAFE LAYOUT

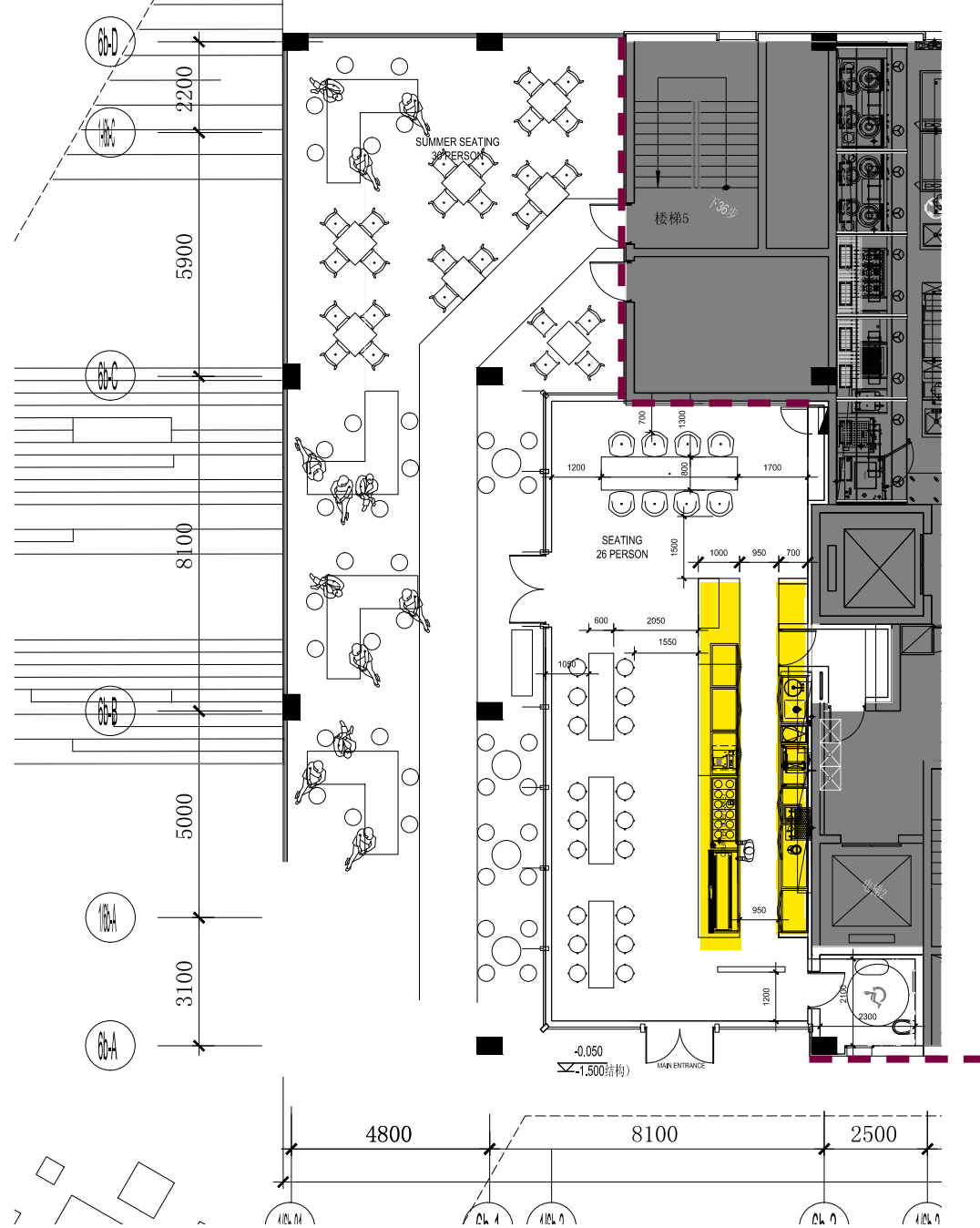

--- EXTERIOR
WALL FINISH

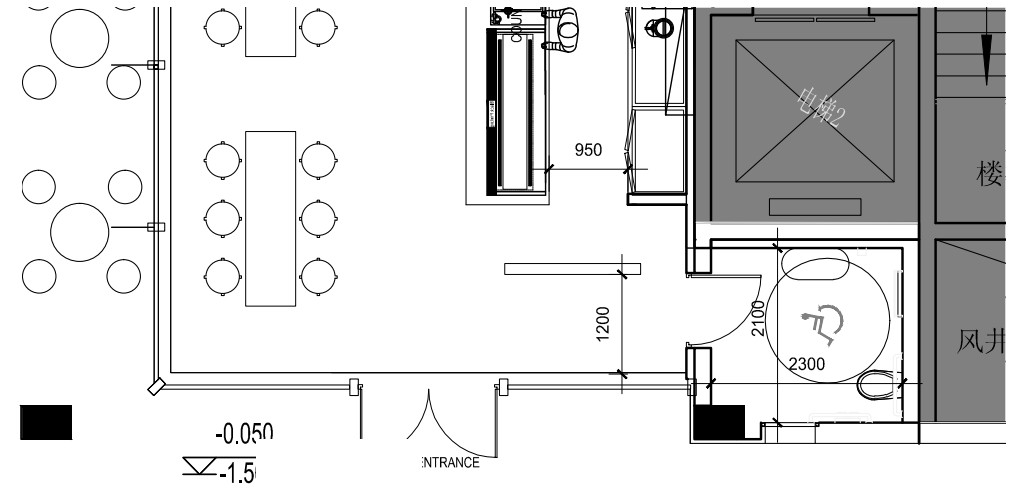

OPTION 1-DISABLED TOILET

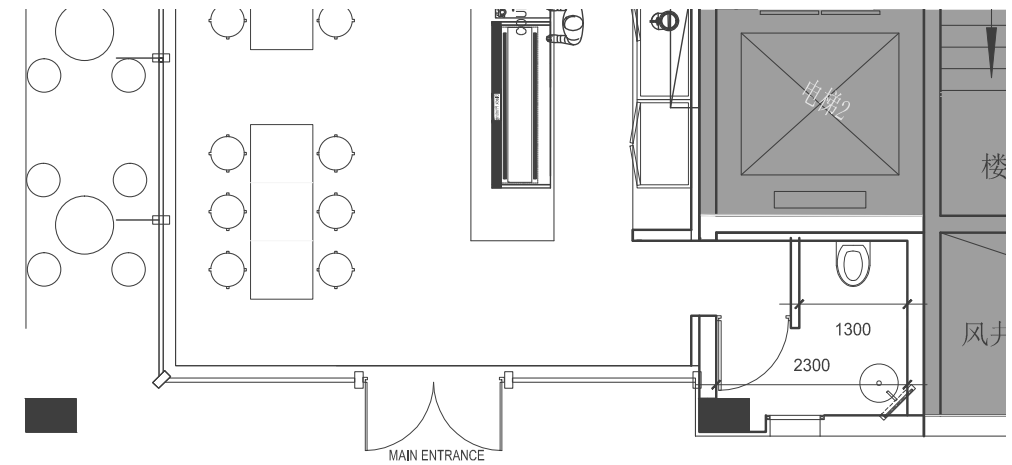

OPTION 2-NORMAL TOILET

CAFE KITCHEN EQUIPMENT

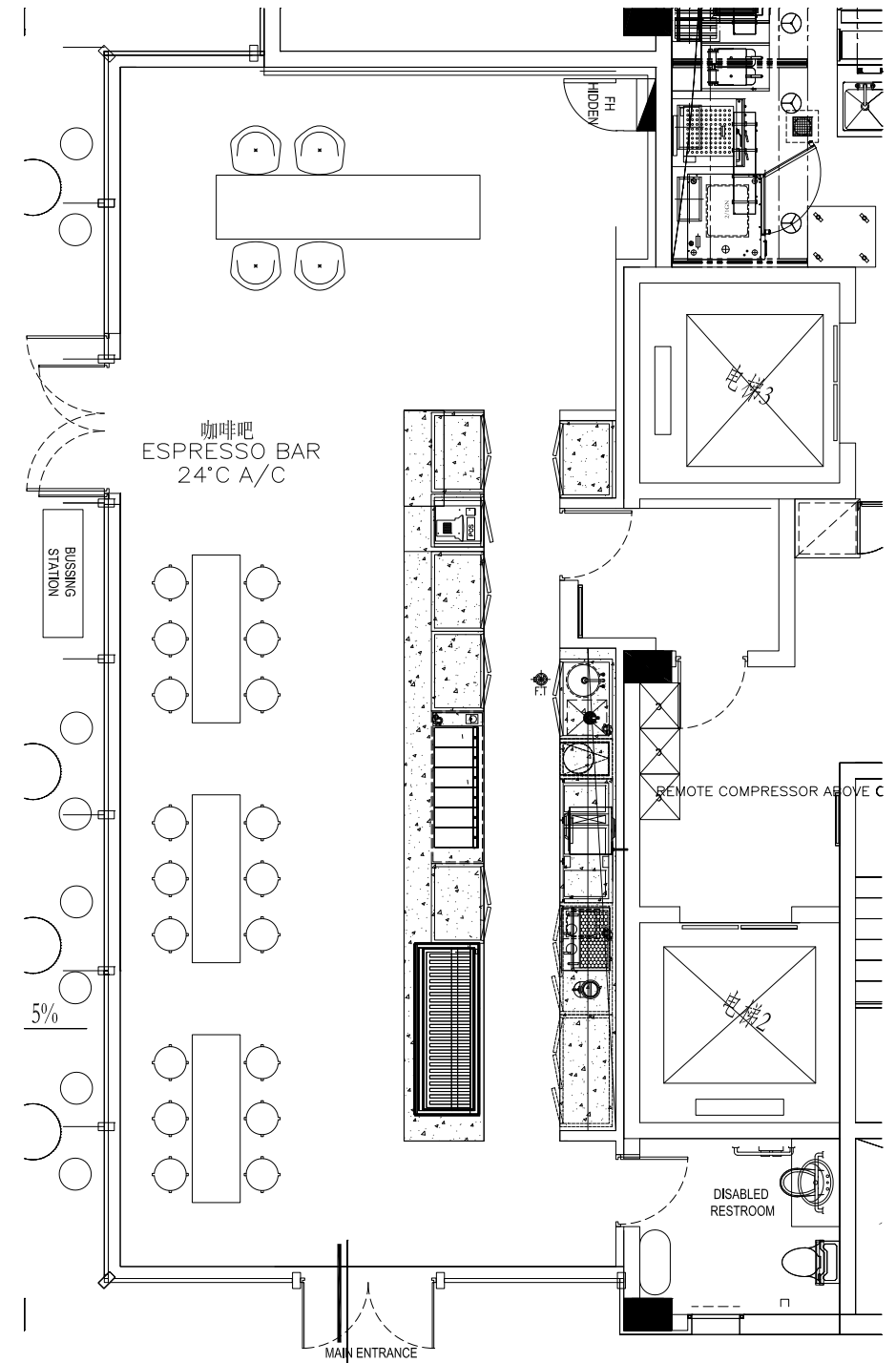

PLAN

CAFE

SKETCH UP VIEW



CAFE

SKETCH UP VIEW



CAFE

SKETCH UP VIEW

